

**PARKS AND RECREATION COMMISSION  
STAFF REPORT**

**MEETING DATE:** February 2, 2016

**AGENDA ITEM NUMBER:** 3E

**APPLICANT:** Scott Fahrenbruch, Deputy Director  
Vern L. Krahn, Senior Park Planner

**REQUEST:** **For Possible Action:** To recommend to the Board of Supervisors approval of a grant application submittal to the Nevada Department of Wildlife for a vault toilet restroom and associated site improvements for the Rifle and Pistol Range and to authorize the Chairperson to sign a letter of support for the project. (Vern L. Krahn / Scott Fahrenbruch)

**GENERAL DISCUSSION:** In March, 2015 the Parks and Recreation Department submitted to the Nevada Department of Wildlife (NDOW) a grant application for security gates at the Carson City Rifle and Pistol Range. Currently, the facility is experiencing a significant amount of vandalism at night. In order to control access to the range after dark, our project will be proposing to install a solar powered security gate on Rifle Range Road approximately one mile from the range. During the day, the gate would remain open but would automatically close at sunset and reopen at sunrise. There will be a number of safety features associated with the gate, including sensors to allow vehicles to “escape”, if caught behind a closed gate after sunset. In addition, there are multiple off-road two track roads accessing the range. Staff will be using metal swing bar gates and large boulders to close this unauthorized access to the range from these two track roads.

Nick Marano, City Manager signed the \$18,708 NDOW grant award documents for the City on September 22, 2015. Currently, City staff has submitted the required paperwork for culture resource review on the project to the State Historic Preservation Office, the Washoe Tribe, and the Bureau of Land Management as required under the 2012 Omnibus Public Lands Management Act Programmatic Agreement. In addition, our department has started the process of contracting with a local fence company to install the gates. Work is expected to begin this spring, and in order to meet the grant requirements, all work associated with this project will need to be completed by June 30, 2016.

Parks and Recreation Department staff is preparing to submit a second grant application to NDOW in March, 2016 for a vault toilet and associated site amenities for the Rifle and Pistol Range (Refer to Exhibit A). The vault toilet will have both a men’s and women’s restroom.

The project will include the vault toilet, clearing/grubbing, site grading, concrete parking pad, and sidewalk for ADA accessibility to the toilet, and all the required striping and signage. The NDOW grant requires a 25% Non-Federal/City match. This match will come from our two project partners: the Carson City Foundation for Parks and Recreation/North Sierra Ladies Gun Club – Shootout Fundraiser (\$3,454.00) and hopefully, the Carson City Sheriff's Department (\$5,000). The Quality of Life (Q-18) Parks Capital - Rifle and Pistol Range project account will make up the match difference. City staff will begin working on this new grant application in February. A very preliminary cost estimate range for this project is between \$55,000 and \$60,000. The deadline for submitting this grant application is March 11, 2016.

Staff is seeking a positive recommendation from the Parks and Recreation Commission to forward on to the Board of Supervisors. The City's grant policy requires any grant application over \$25,000 be approved by the Board of Supervisors prior to a grant application submittal by City staff.

**RECOMMENDED ACTION:**

I move to recommend to the Board of Supervisors approval of a grant application submittal to the Nevada Department of Wildlife for a vault toilet restroom and associated site improvements for the Rifle and Pistol Range and to authorize the Chairperson to sign a letter of support for the project.

**Exhibit A**





Buildings Textures & Professional Site Maintenance & Replacement Park Products Government  
Colors Services & Install Warranty Parts Purchasing  
Sales Region  
Information

### TIOGA DOUBLE VAULT RESTROOM

Fully accessible building



Barnwood Walls in Oatmeal Buff Cedar Shake Roof in Java Brown





| EMBEDDED MATERIALS   |     | QTY                  | UNIT | QTY                |
|----------------------|-----|----------------------|------|--------------------|
| RISE                 | 2   | ONE WAY OVAL 8x1 1/4 | 4    |                    |
| GRAB BAR             | 2   | ANCHOR LEAD 6-8x1    | 4    |                    |
| TP DISPENSER         | 2   |                      |      |                    |
| TOILET PAPER ROLL    | 4-5 |                      |      |                    |
| COAT HOOK            | 2   |                      |      |                    |
| DOOR STOP            | 2   |                      |      |                    |
| SH-1                 | 2   |                      |      |                    |
| BLIND RIVET 1/8x1/4  | 4   |                      |      |                    |
| CXT I.D. TAG         | 2   |                      |      |                    |
| ANCHOR NAIL 1/4x1    | 12  |                      |      |                    |
| ANCHOR NAIL 1/4x3/4  | 8   |                      |      |                    |
| ANCHOR NAIL 3/16x7/8 | 18  |                      |      |                    |
| COL. FT. CONC.       |     | SQ. FT. WEIR         |      | APPROXIMATE WEIGHT |



**Precast Products**  
PROJECT TITLE  
**TIOGA with CHASE**  
CXT STANDARD BUILDING

**NOTICE**  
The information contained herein is proprietary and the intellectual property of CXT Incorporated. The information may only be used by the original recipient for the purpose intended. Reproduction or distribution of this information is strictly prohibited without the prior written consent of CXT Incorporated. By use of this information, CXT Incorporated grants no warranty, express or implied, including a warranty of merchantability or of fitness for a particular purpose.  
CXT Incorporated

| REV.    | DESCRIPTION  | APPROVAL | DATE     |
|---------|--------------|----------|----------|
| SCALE   | 1/4" = 1'-0" | DATE     | 03-28-05 |
| DRAWN   |              | FILE NO. | FD-TWC03 |
| CHECKED |              | PLOT     | RS       |

DWG NO. **TWC-03**  
SHEET  
REV.

**INTERIOR ELEVATIONS**

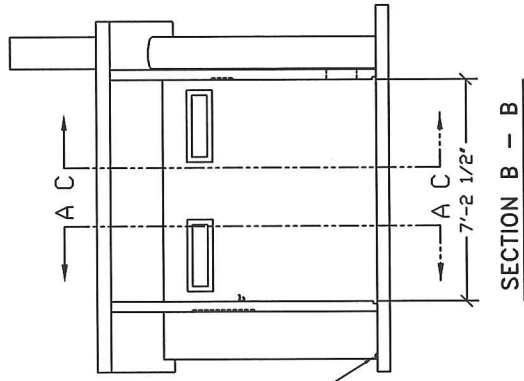

**SECTION B - B**

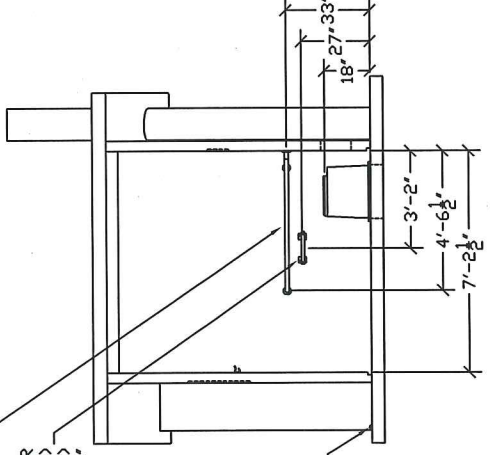

**SECTION D - D**

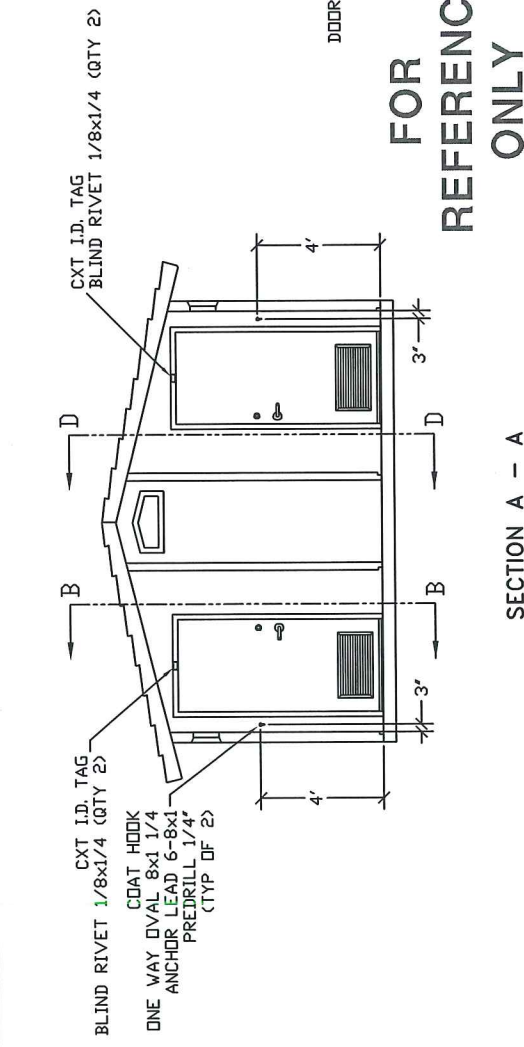

**SECTION A - A**

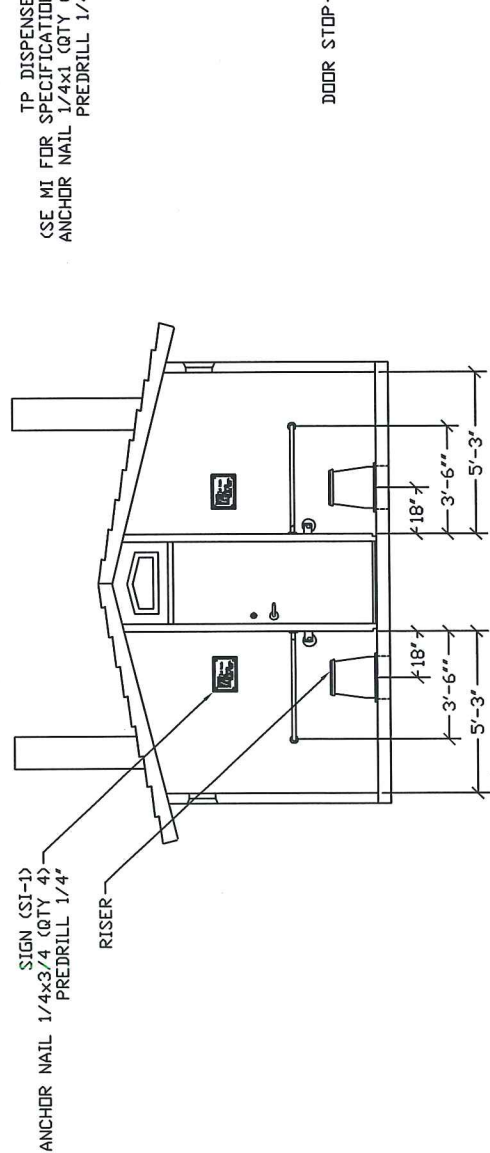

**SECTION C - C**

**FOR REFERENCE ONLY**

- CXT I.D. TAG (QTY 2)
- BLIND RIVET 1/8x1/4 (QTY 2)
- CXT I.D. TAG (QTY 2)
- COAT HOOK
- ONE WAY OVAL 8x1 1/4
- ANCHOR LEAD 6-8x1
- PREDRILL 1/4\"
- (TYP OF 2)

- GRAB BAR
- ANCHOR NAIL 3/16x7/8 (QTY 9)
- PREDRILL HOLE 3/16\" DIA
- TP DISPENSER
- (SEE MI FOR SPECIFICATIONS)
- ANCHOR NAIL 1/4x1 (QTY 6)
- PREDRILL 1/4\"

- SIGN (SI-1)
- ANCHOR NAIL 1/4x3/4 (QTY 4)
- PREDRILL 1/4\"



**Precast Products**

PROJECT TITLE  
**T100A With CHASE**  
**CXT STANDARD BUILDING**

**NOTICE**  
The information contained herein is proprietary and the user of this information is hereby notified that its use may only be used by the original recipient for the purpose intended. Reproduction or distribution of this information is strictly prohibited without the prior written consent of the manufacturer. CXT Incorporated grants no warranty, express or implied, including a warranty of merchantability or of fitness for a particular purpose.  
CXT Incorporated

| REV.    | DESCRIPTION  | DATE     | APPROVAL |
|---------|--------------|----------|----------|
| SCALE   | 1/2" = 1'-0" | DATE     | 03-28-05 |
| DRAWN   |              | FILE NO. | PD-T100A |
| CHECKED |              | PLOT     | 24       |

**FLOOR PLAN**

|         |        |       |      |
|---------|--------|-------|------|
| DWG NO. | TWC-04 | SHEET | REV. |
|---------|--------|-------|------|

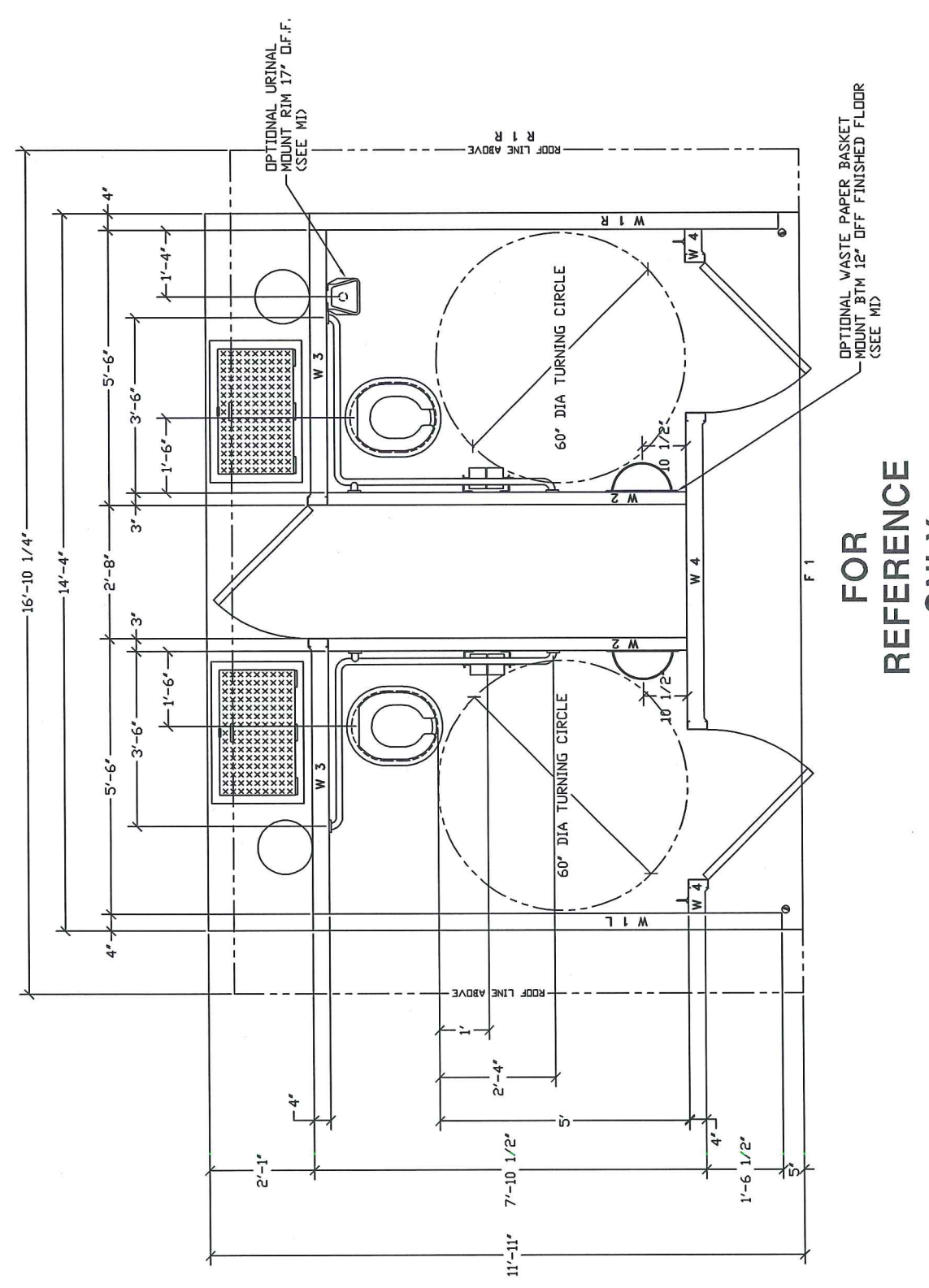

**FOR REFERENCE ONLY**